

# EASY ASSEMBLY AND OPERATION INSTRUCTIONS

MR-123485 Fortune Teller Witch



Please follow the step by step guide and enjoy your Fortune Teller Witch !

## PARTS LIST

- A. Base x 1
- B. Support poles x 2
- C. Hip Frame x 1
- D. Hip Hoop x 1
- E. Upper Body x 1
- F. Hat with Wig x 1

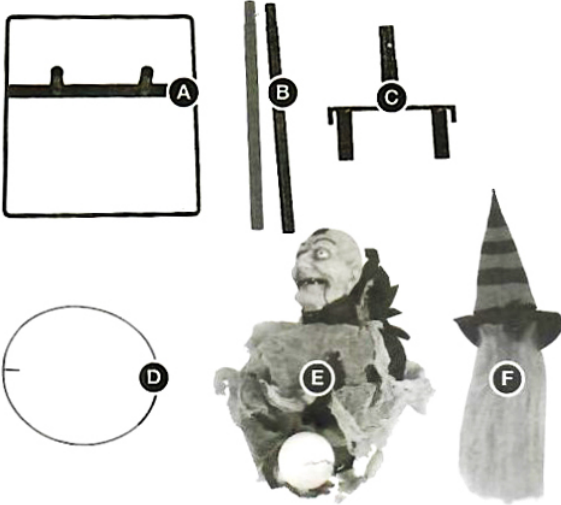

## CARE AND STORAGE INSTRUCTIONS

For best performance operate your item indoors. When not in use, store this product in its original packing. Keep away from heat and moisture.

## WARNING

This item is not a toy and should be used for decoration only. This item contains small parts that can be a choking hazard. Keep all plastic and wire parts away from children. This product is intended for people ages 14 and up.

Please read all instructions carefully before assembling. Save this instruction sheet for future reference.

**BEFORE ASSEMBLING, REMOVE ALL THE ABOVE PARTS FROM BOX. IF ANY PART IS MISSING, PLEASE CONTACT CUSTOMER SERVICE AT [SUPPORT@MORRISCOSTUMES.COM](mailto:SUPPORT@MORRISCOSTUMES.COM), OR BY PHONE 704-332-3304. IN YOUR EMAIL INQUIRY, PLEASE INCLUDE: YOUR ORDER NUMBER, WHO YOU BOUGHT IT FROM, AND WHAT SPECIFICALLY IS WRONG. THANK YOU.**

## ASSEMBLY INSTRUCTIONS

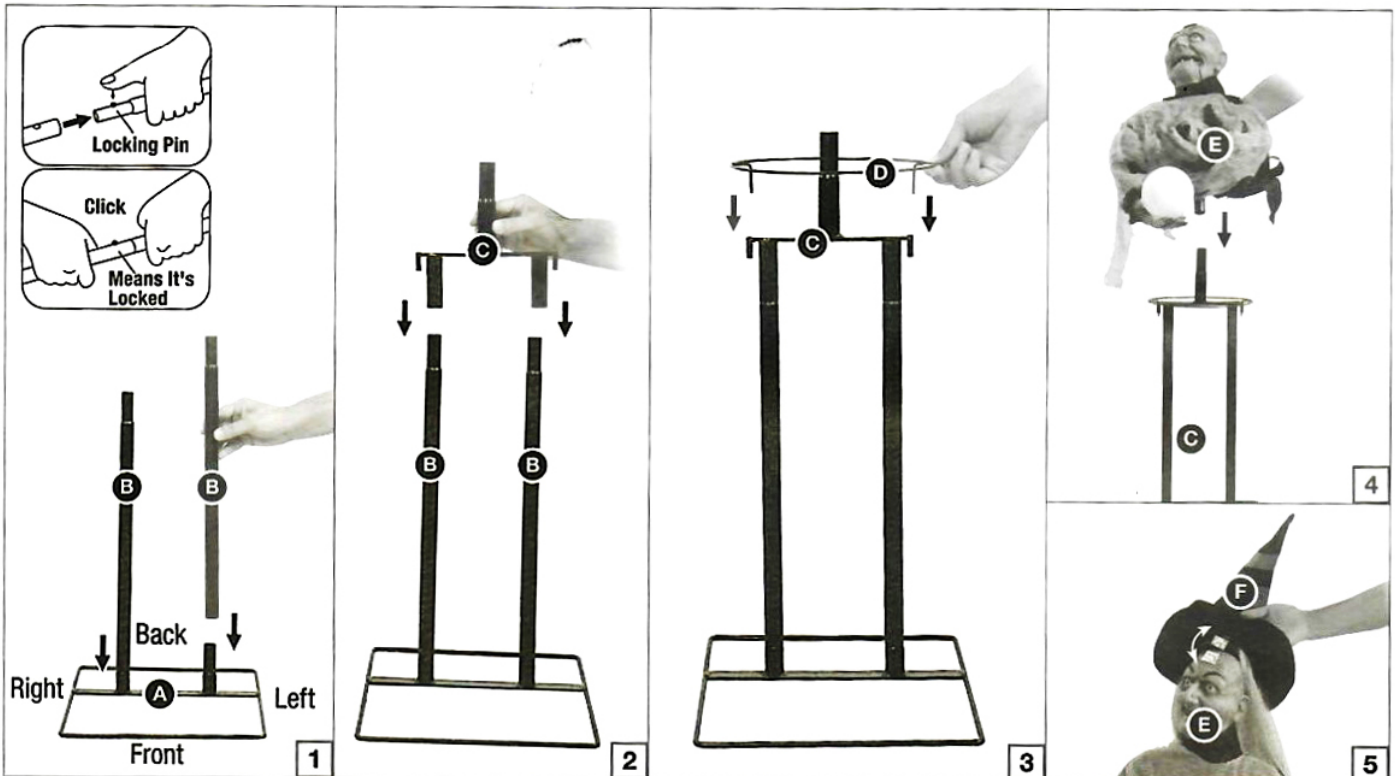

### STEP 1

Note: Throughout the instructions, right and left are relative to the character.

Attach the (B) Support Poles to the (A) Base as shown and secure by aligning the quick connect push buttons into the pre-drilled holes as shown in Figure 1.

Attach the (C) Hip Frame to the (B) Support Poles using the available quick connect push buttons and pre-drilled holes as shown in Figure 2. Lower the (D) Hip Hoop down over the (C) Hip Frame and slide through the slots located on the (C) Hip Frame as shown in Figure 3.

Attach the (E) Upper Body to the (C) Hip Frame and secure by aligning the quick connect push button into the pre-drilled hole as shown in Figure 4.

Attach the (F) Hat with Wig onto the head of the (E) Upper Body with the available hook & loop closures as shown in Figure 5.

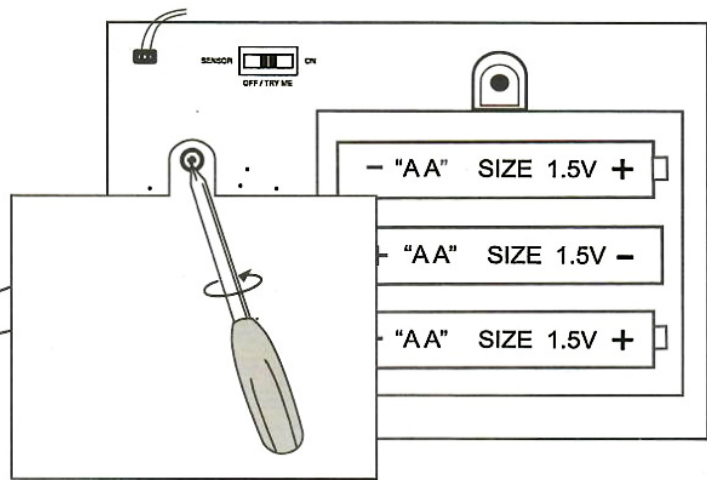
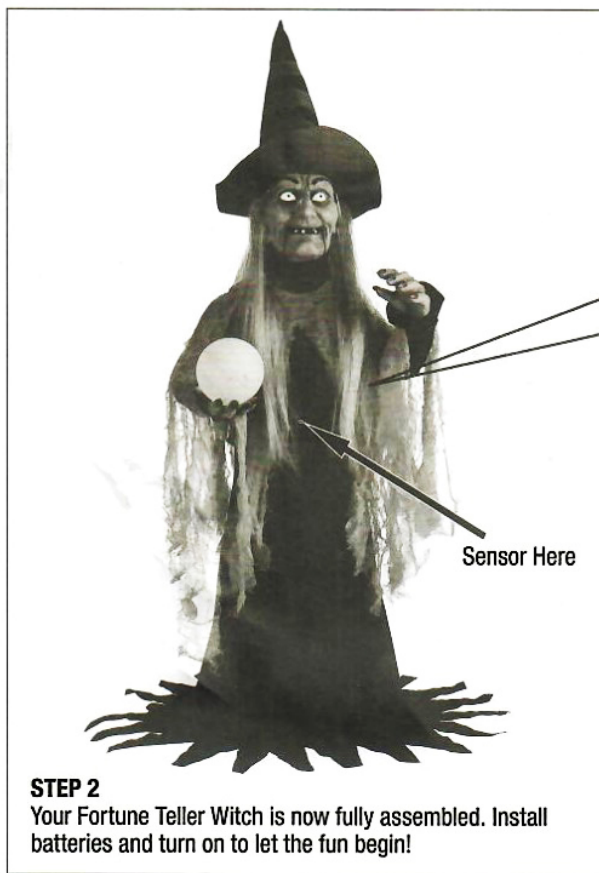

**BATTERY REPLACEMENT INSTRUCTIONS**

Requires 3 x AA 1.5V batteries (Not Included)

You will need a small Phillips head screwdriver.

This is not a toy. For decorative use only.

Locate battery box on product. You must unscrew Phillips head screw before removing battery box cover. After removing or placing batteries into battery box, slide cover into position. Reset screw into position and tighten. Be careful not to overtighten. To activate light turn switch located above batteries to the "ON" position.

**OPERATION INSTRUCTIONS:**

The Fortune Teller Witch has 3 operation settings which can be found on the main Function Control Box inside the (E) Upper Body:

- On: This switch mode will continuously operate the lights, sound, and animation of the item.
- Sensor: This switch mode will activate lights, sound, and animation when the Infra-red (IR) sensor is activated and will operate for 1 audio-cycle with each activation. The Infra-red (IR) sensor has a range of up to 2 m/6.5 ft. and will activate when someone comes within an 80-degree angle from left-to-right, as well as from above and below.
- Off/Try Me: The item will operate for one audio cycle with each Try-Me activation.

This device complies with Part 15 of the FCC Rules. Operation is subject to the following two conditions: (1) This device may not cause harmful interference, and (2) this device must accept any interference received, including interference that may cause undesired operation.

**CAUTION:** Changes or modifications not expressly approved by the party responsible for compliance could void the user's authority to operate the equipment.

**NOTE:** This equipment has been tested and found to comply with the limits for a Class B digital device, pursuant to Part 15 of the FCC Rules. These limits are designed to provide reasonable protection against harmful interference in a residential installation. This equipment generates, uses, and can radiate radio frequency energy and, if not installed and used in accordance with the instructions, may cause harmful interference to radio communications. However, there is no guarantee that interference will not occur in a particular installation. If this equipment does cause harmful interference to radio or television reception, which can be determined by turning the equipment off and on, the user is encouraged to try to correct the interference by one or more of the following measures: Reorient or relocate the receiving antenna, Increase the separation between the equipment and receiver, Connect the equipment into an outlet on a circuit different from that to which the receiver is connected. Consult the dealer or experienced radio/TV technician for help.