

14104245 Studio VBS Directional Sign Instructions

PLEASE READ INSTRUCTIONS BEFORE YOU BEGIN

- Check that all materials are included in your kit.
- Make sure that your work area is large enough to assemble the item.
- Assembly time should be about 30 minutes for two people.

COMPONENTS INCLUDED

- QTY. 1 A) SIGN POST
 QTY. 4 B) POST SUPPORTS
 QTY. 6 C) SHAPED SIGNS
 QTY. 12 D) CLEAR PLASTIC PLUGS

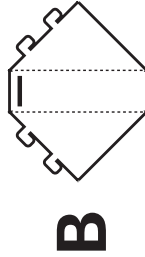

STEP 1:

Fold piece A into a box shape and secure the tabs.

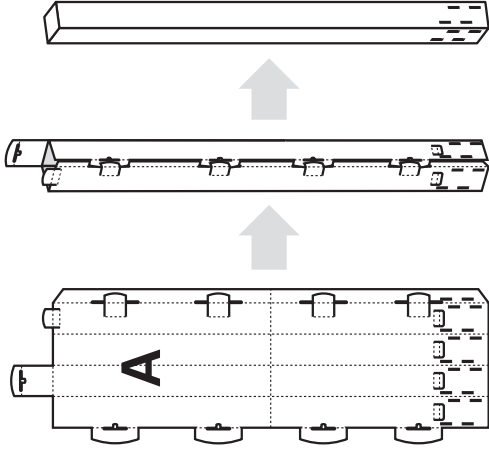

STEP 2:

Fold the sides of B to create a triangular box shape as shown. Lift the flap on A and insert the tabs of B into the four slots on one side of A. To secure, insert the flap into the top slit on B.

Repeat with other B pieces.

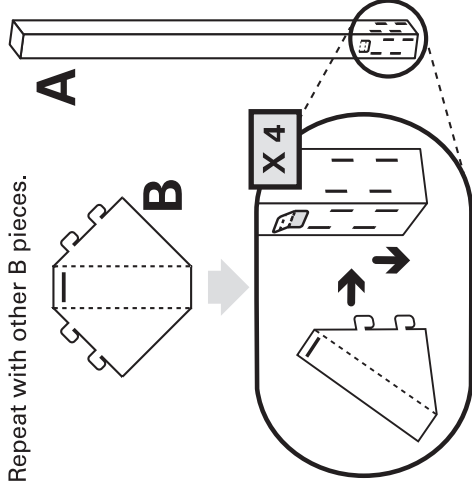

STEP 3:

Use two D pieces to attach one C piece to A. Repeat with other D pieces until assembled.

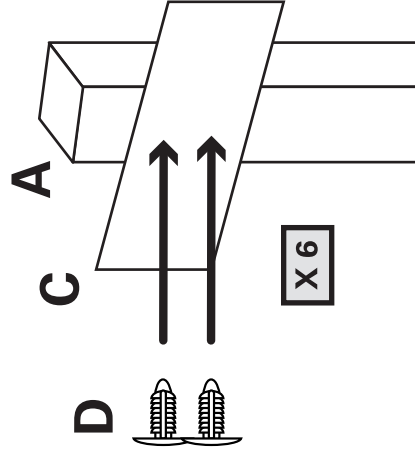

Your Directional Sign is finished!

Have fun with your new directional sign! Use it as a display piece or as part of a scene.

WARNING!!!
 THE DIRECTIONAL SIGN IS NOT CAPABLE OF SUSTAINING HEAVY WEIGHTS.

HELPFUL TIPS:

- When folding the pieces make sure the print is facing outward.
- Follow the diagram below to insert and close the tab openings.

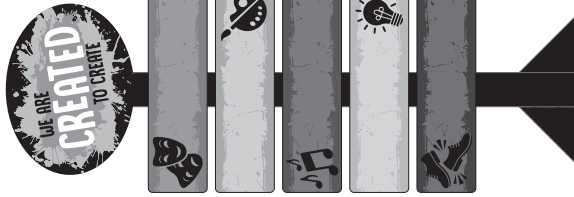
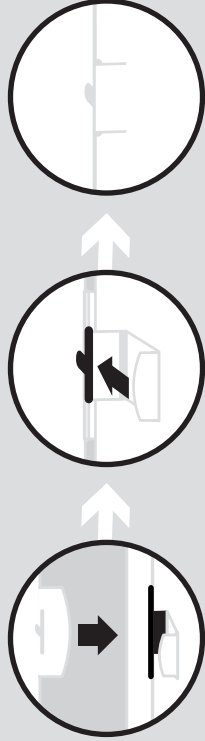

© OTC

Share your fun!



Tag your photo with #orientaltrading on social media!